

# Development and validation of a low-cost simulator for training in gynecological procedures

Raphael Raniere de Oliveira Costa<sup>1</sup>, Marcos Eduardo dos Santos Targino<sup>2</sup>, Pedro Fellippe Pereira da Silva<sup>2</sup>, Jayro Jorge Dantas Gomes<sup>2</sup>, Klécio Fabiano da Silva Feitosa<sup>2</sup>, Rebeca Jerônimo de Aquino Silva<sup>2</sup>, Beatriz Emanuelle Sousa Macedo<sup>2</sup>, and George Dantas de Azevedo<sup>3</sup>

<sup>1</sup>PhD, Escola Multicampi de Ciências Médicas do Rio Grande do Norte, Universidade Federal do Rio Grande do Norte, Caicó, Brazil

<sup>2</sup>Medical Student, Escola Multicampi de Ciências Médicas do Rio Grande do Norte, Universidade Federal do Rio Grande do Norte, Caicó, Brazil

<sup>3</sup>MD, MSc, PhD; Associate Professor, Escola Multicampi de Ciências Médicas do Rio Grande do Norte, Universidade Federal do Rio Grande do Norte, Caicó, Brazil

## Abstract

This study aimed to develop and validate the appearance and functionality of a low-cost simulator for training in gynecological procedures, including speculum examination, hysteroscopy, and intrauterine device (IUD) insertion. This methodological pilot study was conducted between March and June 2025 at a federal university in northeastern Brazil and involved two stages: prototype development/testing and appearance/functionality validation. Twelve Family and Community Medicine residents (mean age: 28 years; 58.3% male) participated. The simulator, classified as low-cost (BRL 202.00 ≈ USD 36), presented medium technological complexity and handcrafted production, enabling all proposed procedures. Internal consistency was high

(Cronbach's  $\alpha = 0.915$ ). Accessibility ( $4.69 \pm 0.62$ ) and usability ( $4.8 \pm 0.4$ ) scored highest, while realism was moderate ( $4.0 \pm 1.06$ ). Significant correlations were observed between versatility and usability ( $\rho = 0.714$ ;  $p < 0.01$ ) and between technology and realism ( $\rho = 0.543$ ;  $p < 0.01$ ). Findings support appearance and functionality validity only; educational effectiveness and skill transfer were not assessed. No objective measures of skill acquisition, error reduction, or transfer to clinical performance were evaluated in this study. The simulator proved accessible, safe, and pedagogically useful, supporting competency-based and sustainable training in sexual and reproductive health.

**Keywords:** Gynecology, simulation, educational technology, low-cost equipment, health education.

**Date submitted:** 12-November-2025

**Email:** Raphael Raniere de Oliveira Costa (raphaelraniere@hotmail.com)

This is an open access journal, and articles are distributed under the terms of the Creative Commons Attribution-Non Commercial-Share Alike 4.0 License, which allows others to remix, tweak, and build upon the work non-commercially, as long as appropriate credit is given and the new creations are licensed under the identical terms.

## INTRODUCTION

Training in sexual and reproductive health requires supervised practical experience in procedures such as speculum examination, hysteroscopy, and IUD insertion for individuals with a uterus and vagina. However, limited access to controlled training environments restricts skill development and learner safety.<sup>1,2</sup> Clinical simulation is an established strategy for safe and structured procedural learning, enabling repetition, error recognition, and progressive skills acquisition.<sup>1,2</sup> Simulators may be physical, technological, or service-based representations<sup>3</sup> and are commonly classified as low-, medium-, or high-fidelity, according to complexity and cost.<sup>4,5</sup>

Citation: Raniere de Oliveira Costa R, Eduardo dos Santos Targino M, Fellippe Pereira da Silva P, Jorge Dantas Gomes J, Fabiano da Silva Feitosa K, Jerônimo de Aquino Silva R, Emanuelle Sousa Macedo, and Dantas de Azevedo G. Co-designing education with and for community health workers: creating a bridge to care. *Educ Health* 2026;39:225-230

**Online access:** [www.educationforhealthjournal.org](http://www.educationforhealthjournal.org)

DOI: 10.62694/efh.2026.532

Published by The Network: Towards Unity for Health

Commercial simulators are often expensive and inaccessible, especially in low- and middle-income countries. Low-cost models made from reproducible materials are a sustainable alternative without compromising educational value.<sup>5,6,7,8,9-10</sup> Simulation-Based Education (SBE) improves psychomotor skills and reduces learner anxiety but requires trained faculty and adequate infrastructure.<sup>11,12</sup> Resource constraints reinforce inequities and reliance on traditional observational teaching.<sup>13,14</sup>

Teaching gynecological procedures also involves ethical and communication aspects, including privacy and modesty. Simulation enables technical and relational skills practice in a safe environment. In Brazil, IUD use among women aged 15–49 remains low (~4%),

indicating training gaps.<sup>15</sup> Expanding access to procedural simulation is therefore relevant to workforce qualification.

**Aim of the study**

This study aimed to develop and validate the appearance and functionality of a low-cost simulator for speculum examination, hysteroscopy, and IUD insertion.

**METHODS**

**Study Design**

A methodological applied study was conducted at a public university in Rio Grande do Norte, Brazil. The process included prototype development/testing and appearance/functionality validation with medical residents. Ethical approval was granted (CAAE 6,974,590). The design followed pilot-stage validation principles focused on appearance and functionality domains.

**Stage 1: Development and Prototype Testing**

The simulator integrates three gynecological procedures in a single platform to reduce fragmentation seen in commercial devices. Materials included a trapezoidal wooden base (20° incline), silicone genital structure, acrylic cover, removable elastomeric cervix, silicone uterus, and an Arduino UNO microcontroller with a piezoelectric sensor that emits light and sound when the uterine fundus is reached. Expert-guided refinement ensured anatomical coherence, stability, and adequate tactile resistance.

**Stage 2: Validation**

Twelve Family and Community Medicine residents participated after providing informed consent.

The small and homogeneous sample reflects a preliminary validation phase and was not intended to support broad generalization. Multicenter validation with larger and more diverse professional groups is planned for future studies.

Participants performed the three procedures and completed:

- Sociodemographic questionnaire
- Low-Cost Simulator Assessment Instrument (IESBJ), with 25 items across six domains: cost, accessibility, technology/manufacturing, realism, versatility, and usability.<sup>7</sup>

**Data Analysis**

SPSS 24 was used. Descriptive statistics summarized scores. Cronbach’s  $\alpha$  assessed internal consistency ( $\geq 0.70$  acceptable). Spearman’s  $\rho$  tested domain correlations ( $p < 0.05$ ).

**RESULTS**

**Simulator Overview**

The device was classified as medium-technology and handcrafted, suitable for low-resource settings. Anatomical dimensions supported the execution of all three procedures (**Fig. 1**).

Production cost totaled BRL 202 ( $\approx$  USD 36), substantially lower than commercial simulators exceeding USD 1,000–100,000.<sup>16</sup> These higher-cost models typically include high-fidelity pelvic trainers and sensor-based gynecological task simulators described in prior studies.<sup>6,11</sup>

**Table 1: Final simulator — top and lateral views showing the identification of structural and anatomical components. Source: Authors’ own elaboration.**

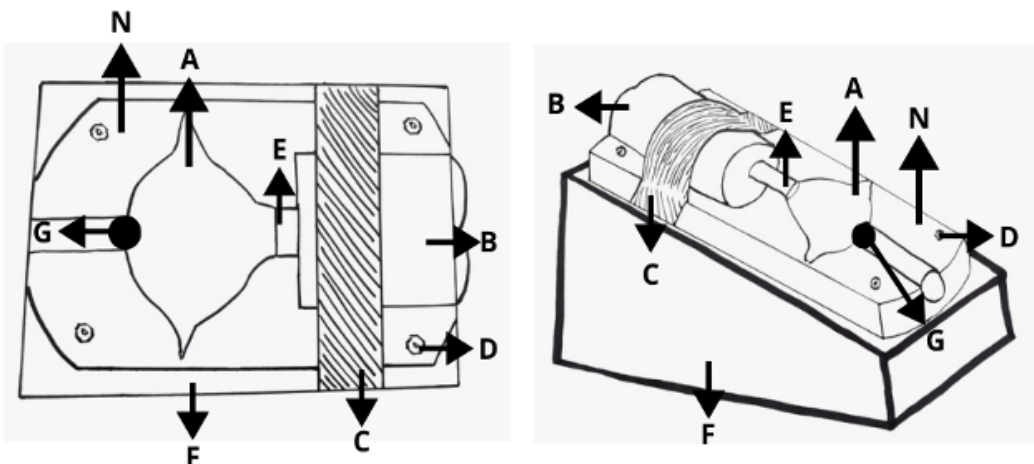

**Validation Outcomes**

Cronbach's  $\alpha = 0.915$  confirmed excellent internal consistency. Participants (mean age = 28 years; 58.3%

male) rated the simulator highly across most domains (Table 1 summary):

**Table 1: Global assessment of the low-cost gynecological simulator according to the dimensions of the Low-Cost Simulator Assessment Instrument**

Dimension	Mean $\pm$ SD	Median (P25–P75)	Mode	Min	Max
Cost	4.64 $\pm$ 0.60	5.0 (4.0–5.0)	5.0	2.0	5.0
Accessibility	4.69 $\pm$ 0.62	5.0 (5.0–5.0)	5.0	3.0	5.0
Technology, manufacturing, and reproducibility	4.32 $\pm$ 0.80	5.0 (4.0–5.0)	5.0	1.0	5.0
Realism	4.00 $\pm$ 1.06	4.0 (4.0–5.0)	4.0	2.0	5.0
Versatility	4.53 $\pm$ 0.70	5.0 (4.0–5.0)	5.0	2.0	5.0
Usability	4.80 $\pm$ 0.40	5.0 (5.0–5.0)	5.0	4.0	5.0

Overall, the results demonstrate very high acceptance in accessibility, usability, and versatility domains, with acceptable but comparatively lower realism scores, supporting feasibility for low-cost procedural training.

Accessibility and usability were top-rated, confirming portability, intuitive handling, and safety. Realism, though acceptable, was lower due to limited tactile fidelity. Participant comments indicated that realism limitations were mainly related to reduced tactile feedback, simplified tissue resistance, and less detailed cervical and vaginal anatomical texture, findings consistent with other low-cost simulator studies.<sup>7,12</sup>

Correlation analysis revealed positive relationships between usability  $\times$  versatility ( $\rho = 0.714$ ;  $p < 0.01$ ), and technology  $\times$  realism ( $\rho = 0.543$ ;  $p < 0.01$ ), suggesting coherence among domains. The moderate correlation between cost  $\times$  realism ( $\rho = 0.483$ ;  $p < 0.01$ ) indicated perceived balance between affordability and fidelity.

Overall, participants considered the simulator feasible, versatile, and pedagogically effective for procedural training. Figure 2 shows its practical application and structure during simulated sessions. **DISCUSSION**

**Figure 2: Practical use of the developed simulator: (a) simulated procedure by a student under faculty supervision; (b) anteroposterior view of external genitalia and model; (c) posterosuperior view during intrauterine device (IUD) insertion. Source: Authors.**

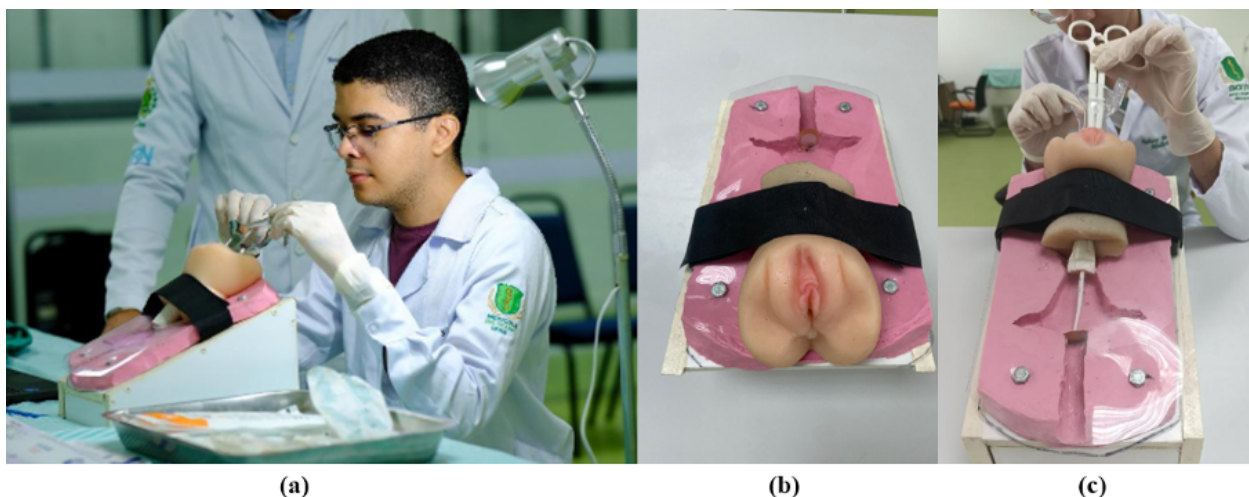

This study presents an integrated, affordable simulator addressing an important gap in gynecological procedural training. Combining three procedures in a single device improves efficiency compared with existing fragmented commercial solutions.

This validation specifically addresses face (appearance) and functionality validity and should not be interpreted as evidence of educational effectiveness or competency gain. Outcomes related to performance improvement were outside the scope of the present study design.

Simulation-based education improves learner confidence and standardizes exposure but remains unevenly implemented in resource-limited contexts.<sup>13,14</sup> The present simulator addresses cost and infrastructure barriers using simple materials and embedded sensory feedback. Its cost ( $\approx$  USD 36) contrasts sharply with high-fidelity and 3D-printed systems. Functionally, it compares favorably with previous designs<sup>17-18</sup> while maintaining multifunctionality.

### **Pedagogical Implications**

High usability and accessibility align with experiential learning principles, enabling repeated safe practice and the development of communication skills. Correlations among realism, technology, and usability suggest that perceived fidelity contributes to engagement.

Moderate realism scores are consistent with low- to medium-fidelity devices. Material refinement may improve haptic performance without major cost increases.

However, because only perception-based measures (IESBJ) were used, conclusions must be limited to user-rated appearance and functionality attributes.

### **Sustainability and Social Accountability**

The handcrafted, reusable design supports environmentally responsible simulation practices.<sup>19,20</sup> Multifunctionality reduces material use and production burden. Expanding equitable access to skills-based education, it reinforces social accountability aligned

with Brazil's Unified Health System (SUS), UNESCO,<sup>21,22</sup> and The Network: Towards Unity for Health.<sup>23</sup> The simulator is used in a clinical skills laboratory.

The simulator is currently under patent filing with the Brazilian National Institute of Industrial Property (INPI). The authors declare that there is presently no commercial licensing agreement or financial commercialization in place. This intellectual property status does not influence data collection, analysis, or reporting.

There are no conflicts of interest related to commercial exploitation at the time of submission (March 2026).

### **Comparison with Existing Literature**

Findings are consistent with other low-cost simulation studies in which high usability compensates for moderate realism.<sup>7,12</sup> The high  $\alpha$  value supports instrument reliability and reproducibility.

### **Limitations**

The validation sample was small (n=12). This should be interpreted as a pilot, preliminary validation study. Participants were limited to Family Medicine residents. Objective performance outcomes were not measured.

Future research should include gynecologists and other frontline professionals performing these procedures in primary care and remote settings, as recommended by the reviewers.

### **Conclusion**

The low-cost simulator demonstrated reliable appearance and functionality validity for training in speculum examination, hysterometry, and IUD insertion. It combines affordability, usability, and sustainability in a multifunctional educational device. Educational effectiveness and clinical skill transfer were not evaluated and should be addressed in future multicenter studies. It represents a practical strategy to expand equitable access to procedural training and support competency-based reproductive health education.

## **References**

1. Rodrigues BD, Loureiro CFAC, Castanho Cavaleiro de Macêdo A, Andrade MC, Ramos SR, Mainardi CR, Rama CH, Botelho NM. Training model for intrauterine device insertion. *Revista Brasileira de Educação Médica*. 2019; 43(4):47-53. <https://doi.org/10.1590/1981-52712015v43n4RB20180167>
2. Vidotti SP, Batista NA. Clinical simulation in the training of obstetrics and gynecology residents from the perspective of medical residency programs. *Revista Brasileira de Ginecologia e Obstetrícia*. 2023; 45(5):266-272. <https://doi.org/10.1055/s-0043-1770127>

3. Shah A, Choby G, Cordero J, et al. Simulation-based education and team training. *Otolaryngologic Clinics of North America*. 2019; 52(6):995-1003. <https://doi.org/10.1016/j.otc.2019.08.017>
4. Costa RRO, Oliveira Neto AV, Moron RA, et al. Types and purposes of simulation in undergraduate nursing education: an integrative literature review. *Revista Baiana de Enfermagem*. 2016; 30(3). <https://doi.org/10.18471/rbe.v30i3.16589>
5. Knobel R, Costa RRO. Making and using low-cost simulators: experiences in medicine and nursing. In: Associação Brasileira de Educação Médica. *Simulação em saúde para ensino e avaliação: conceitos e práticas*. São Paulo: Cubo Multimídia; 2021. p. 214-224.
6. Dodge LE, Hacker MR, Schatzkin E, et al. Assessment of a high-fidelity mobile simulator for intrauterine contraception training in ambulatory reproductive health centres. *Journal of European CME*. 2016; 5(1):30416. <https://doi.org/10.3402/jecme.v5.30416>
7. Costa RRO, Oliveira Neto AV, Moron RA, et al. Development and content, and face validation of the low-cost simulators evaluation instrument. *Clinical Simulation in Nursing*. 2024; 91:101539. <https://doi.org/10.1016/j.ecns.2024.101539>
8. Costa RRO, Oliveira Neto AV, Moron RA, et al. Technological innovation in medical education: the experience of a Brazilian public university. *Journal of Medicine and Health Promotion*. 2021; 6:363-375.
9. De Oliveira-Costa RR, Costa RRO, Moron RA, et al. Low-cost simulator for health teaching: concept analysis. *Revista Latinoamericana de Simulación Clínica*. 2024; 6(2):85-94. <https://doi.org/10.35366/117467>
10. Araújo MS. Construction, validation, and evaluation of the effectiveness of a low-cost simulator aimed at teaching medication administration to infants [dissertation]. Natal (BR): Universidade Federal do Rio Grande do Norte; 2024.
11. Nippita S, Moktar C, Lohr PA, et al. Randomized trial of high- and low-fidelity simulation to teach intrauterine contraception placement. *American Journal of Obstetrics and Gynecology*. 2018; 218(2):258.e1-258.e11. <https://doi.org/10.1016/j.ajog.2017.11.553>
12. Antequera Moron R, Costa RRO, Oliveira Neto AV, et al. Construction of a simulation scenario and a low-cost simulator for teaching thoracentesis procedural technique: a validation study. *BMC Medical Education*. 2025; 25:975. <https://doi.org/10.1186/s12909-025-07381-7>
13. Robinson SJA, Khan KS, Ross DA, et al. Simulation-based education of health workers in low- and middle-income countries: a systematic review. *Global Health: Science and Practice*. 2024; 12(6):e2400187. <https://doi.org/10.9745/GHSP-D-24-00187>
14. Ismail FW, Ghazal Aswad N, Khan Y, et al. Challenges and opportunities in the uptake of simulation in healthcare education in the developing world: a scoping review. *MedEdPublish*. 2024; 14:38. <https://doi.org/10.12688/mep.20271.1>
15. Brasil. Instituto Brasileiro de Geografia e Estatística (IBGE). *Pesquisa Nacional de Saúde 2019: informações sobre saúde sexual e reprodutiva – Brasil e grandes regiões*. Rio de Janeiro: IBGE; 2020. Available from: <https://biblioteca.ibge.gov.br/visualizacao/livros/liv101761.pdf>.

16. Souza FX, Rodrigues JC, Andrade JD, Oliveira CM, Barbosa AL, Brandão AD. Modelo simulador de baixo custo para treinamento de septoplastia. *Revista Eletrônica Acervo Saúde*. 2020; suppl(42). <https://doi.org/10.25248/reas.e2827.2020>
17. Shaikh BT, Hafeez A, Pasha O, et al. Reinvigorating postpartum intrauterine contraceptive device use in Pakistan: an observational assessment of competency-based training of health providers using low-cost simulation models. *BMC Medical Education*. 2020; 20(1):1-9. <https://doi.org/10.1186/s12909-020-01948-9>
18. Andrade AG, Nascimento LC, Louro TQ, Alves KS, Silva RC, Santos PD. Training model for intrauterine device insertion. *Revista Brasileira de Educação Médica*. 2018; 42(4):129-135. <https://doi.org/10.1590/1981-52712018v42n4RB20180007>
19. Marsack JE, Patel L, Collins H, et al. Best practices for environmental sustainability in healthcare simulation education: a scoping review. *Sustainability*. 2025; 17:6624. <https://doi.org/10.3390/su17146624>.
20. Ma Y, Han S. Carbon-neutral hand surgery: simple changes to reduce carbon footprint. *Plastic Surgery (Oakville)*. 2024; 32(1):108-112. <https://doi.org/10.1177/22925503221088839>
21. Brasil. Ministério da Saúde. Secretaria de Ciência, Tecnologia e Insumos Estratégicos. Departamento de Ciência e Tecnologia. Política nacional de ciência, tecnologia e inovação em saúde. 2nd ed. Brasília: Editora do Ministério da Saúde; 2008.
22. UNESCO. Education for sustainable development and the SDGs: learning to act, learning to achieve. Paris: UNESCO; 2018. Retrieved November 10, 2025, from: [https://www.uncclearn.org/wp-content/uploads/library/gap\\_pn1\\_\\_esd\\_and\\_the\\_sdgs\\_policy\\_brief\\_6\\_page\\_version\\_.pdf](https://www.uncclearn.org/wp-content/uploads/library/gap_pn1__esd_and_the_sdgs_policy_brief_6_page_version_.pdf).
23. The Network: Towards Unity for Health (TUFH). Communities of Practice. Retrieved November 10, 2025, from: <https://thenetworktufh.org>.